

LSR

KÖNIG
康尼格

Micro Injection Molding Machine

微型精密注塑设备

设备仅需0.4m²生产空间，适用于对精度要求高，注胶量<5g的液态硅橡胶产品。设备重复精度高，工艺稳定，无需使用昂贵大型的专用设备，帮助客户实现经济型生产，提高竞争力。

Suitable for liquid silicone rubber products with high precision and quality <5g. The equipment has high repetition accuracy, stable process. There only needs 0.4 m² production space, no need to use expensive and large-scale special equipment, to help customers start economic production.

接口 Joint

特制接口，对进料模块进行可靠密封，保持LSR材料的洁净度

Special designed joint to seal the feeding module reliably and keep the cleanliness of LSR material.

射嘴 Nozzle

气动射嘴

出胶稳定无漏胶

Aerodynamic control nozzle, material inject stable without leakage.

PREMIXED FEEDING SYSTEM 预混合供料系统

- 可以灵活使用AB料预混合的灌装胶料管
- 不需要连接AB胶供料系统
- 方便多台设备同时生产
- 快速低成本的实现批量生产
- Flexible use of pre-mixed AB rubber pipe
- No need to connect AB material feeding system
- Easy to start production with multiple equipment
- For efficiency and low cost batch production

WITH FEEDING SYSTEM 直接搭载供料系统

- 灵活搭载第三方供料系统
- 更精确灵活的AB胶混料
- 与行业领先制造商紧密合作
- 完整的微量硅胶注塑解决方案
- Flexible with 3rd-party feeding system
- More accurate for AB rubber mixtures
- Working closely with leading manufacturers in this industry
- Provide a total solution for micro-silicone injection molding

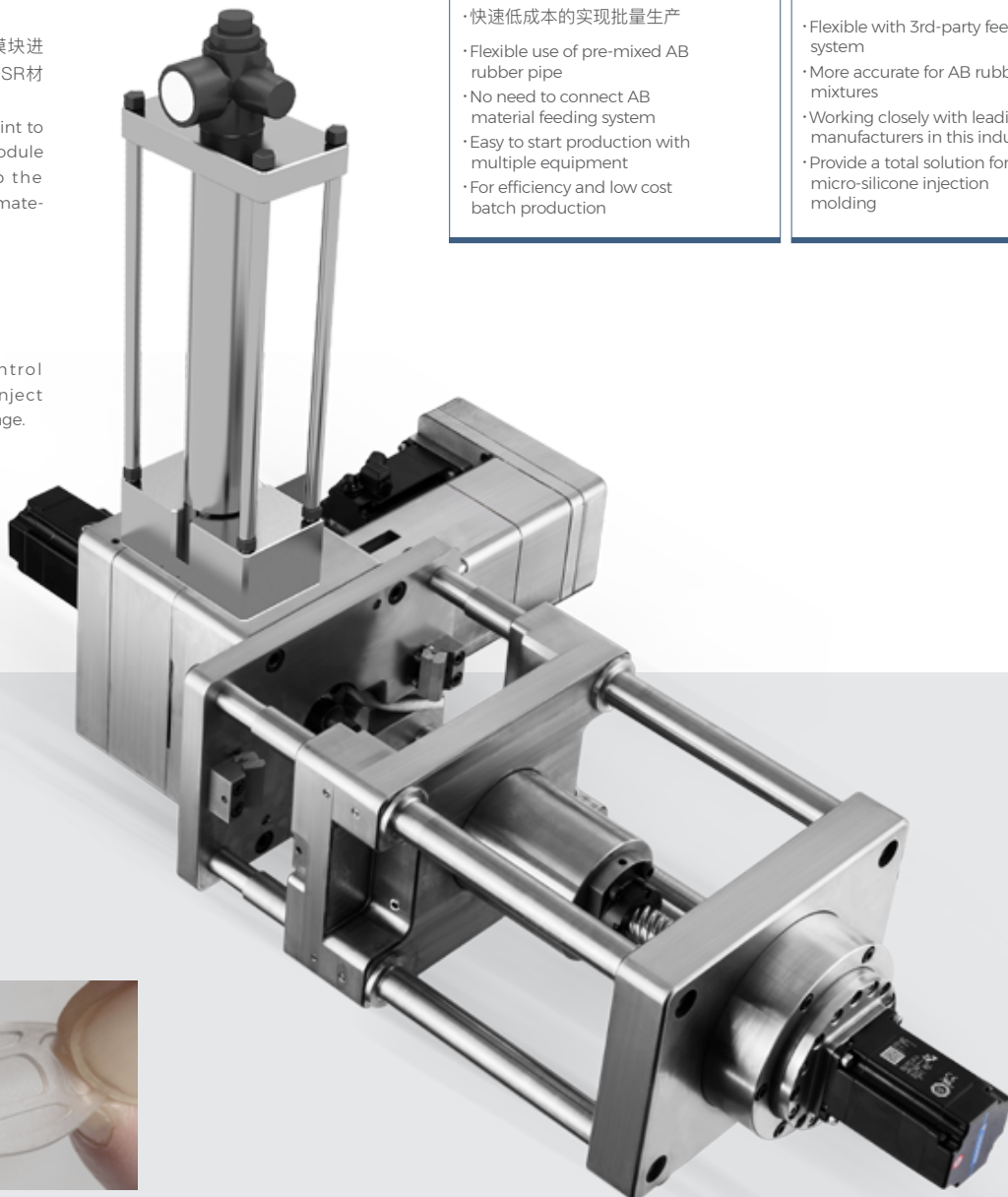

Precision Forming, Precision Extraction We understand the whole process

精准成型 | 精确提取 | 我们了解整个工艺过程

扁平螺杆直径 Screw Diameter	∅80 mm
柱塞直径 Plunger Diameter	∅10 / ∅12 / ∅14 mm
螺杆转速 Screw Speed	30 rpm/min
注射行程 Screw Stroke	Max 35 mm
注射压力 Injection Pressure	0-3940 / 0-2742 / 0-2060 bar
注射速度 Injection Speed	12.5 mm/sec
最大射出量 Max Injection Volume	3 / 4.5 / 5 CC
合模力 Mold Clamping force	3 ton
合模速度 Mold Clamping Speed	12.6 mm/sec(额定400w3000转)
开闭模行程 Mold Clamping Stroke	100 mm
架模尺寸 Die Size	160×130×96 mm
顶出行程 Ejector Stroke	10 mm
热嘴型号 Hot Runner	No.1866
伺服马达 Servo Motor	400 w×3 pc
电热功率 Power Consumption(excl.heat)	1600 w
电源规格 Electrical Source	AC220 V
机器尺寸 Machine Size (LxWxH)	930×550×520 mm
机器重量 Machine Weight	98 kg

全过程压力控制 Whole Process Pressure Control

通过设定进料压力，伺服马达扭矩精确进行全过程压力控制，由精密传感器监测，实现优异的材料流动性。

To ensure excellent material fluidity, feeding pressure, servo motor torque is precisely controlled in the whole process, and monitored by precise sensors.

全过程温度控制 Whole Process Temperature Control

带温控器的冷水机对流动至射嘴的材料温度精准控制，根据胶料不同灵活调节。Water cooler precisely control material temperature from convection channel to nozzle, flexibly adjusting according to different material.

高重复精度成型系统 High Precision Repetitive Molding System

伺服马达通过控制运动距离保证精准的射胶量；通过加热器精确控制模具温度，保证LSR产品成型品质，带来高重复精度。

Servomotor guarantees precise injection quantity by controlling moving distance, and mold temperature control by heater to ensure LSR product forming quality with high repetition accuracy.

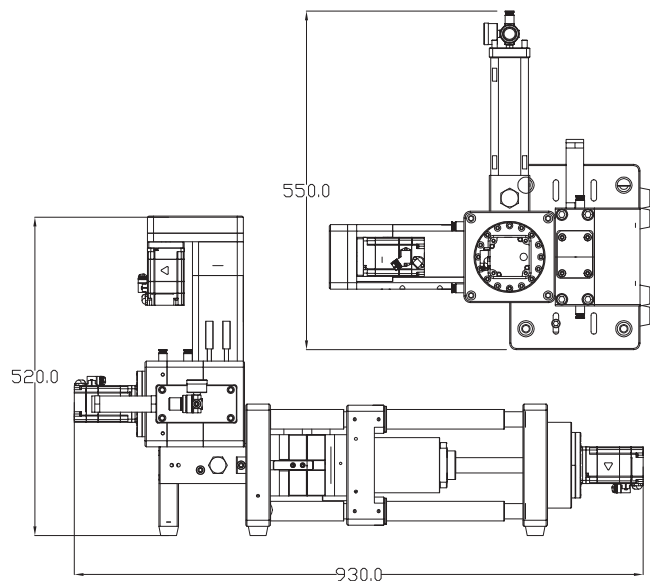

可选设备 Accessories

- 工作台
Workbench
- 冷水机
Chiller
- 液态硅橡胶供料系统
LSR Feeding System

